

# GENERAL ARRANGEMENT TYPICAL FLOOR PLAN

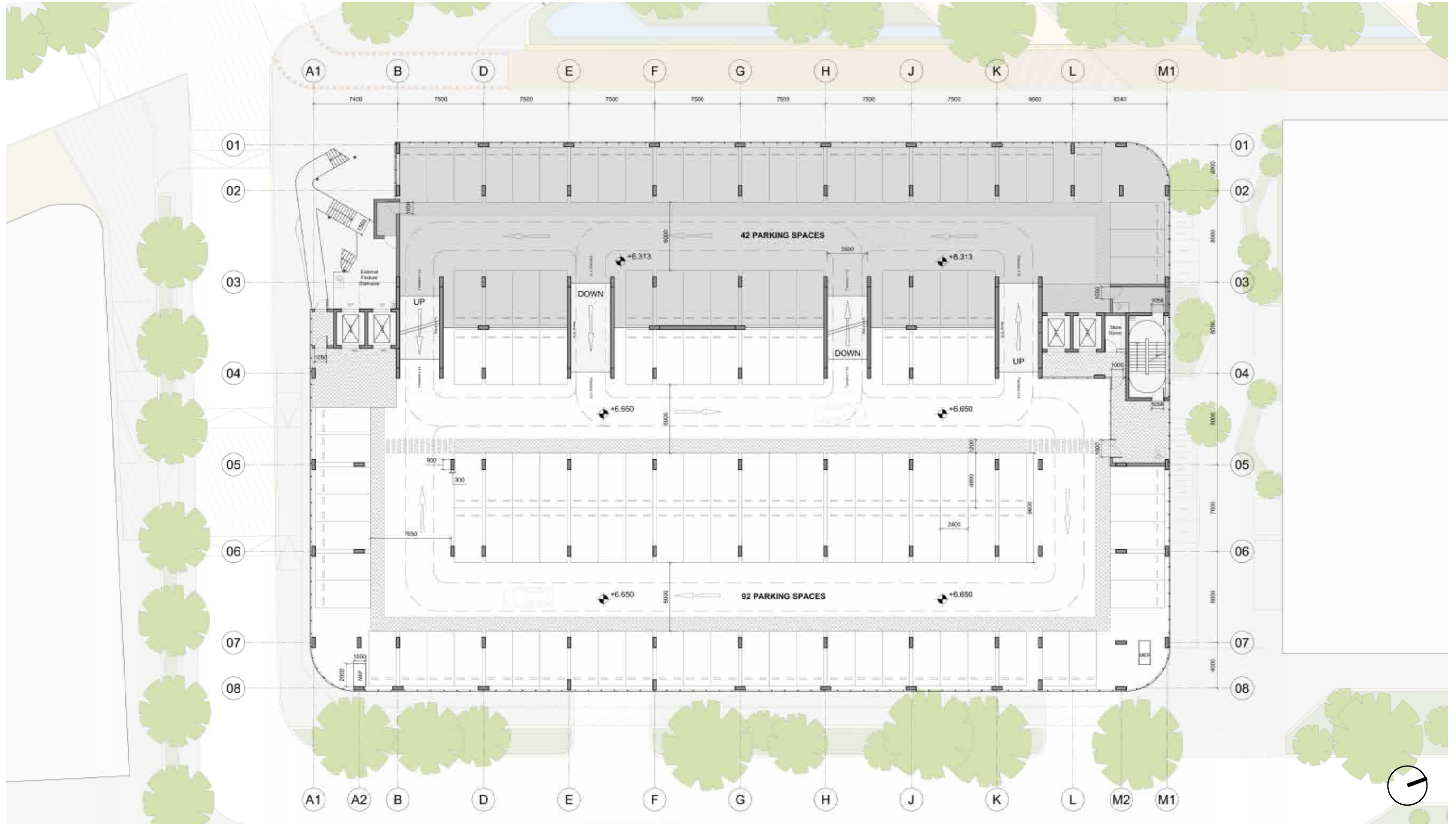

# GENERAL ARRANGEMENT FOURTH FLOOR PLAN

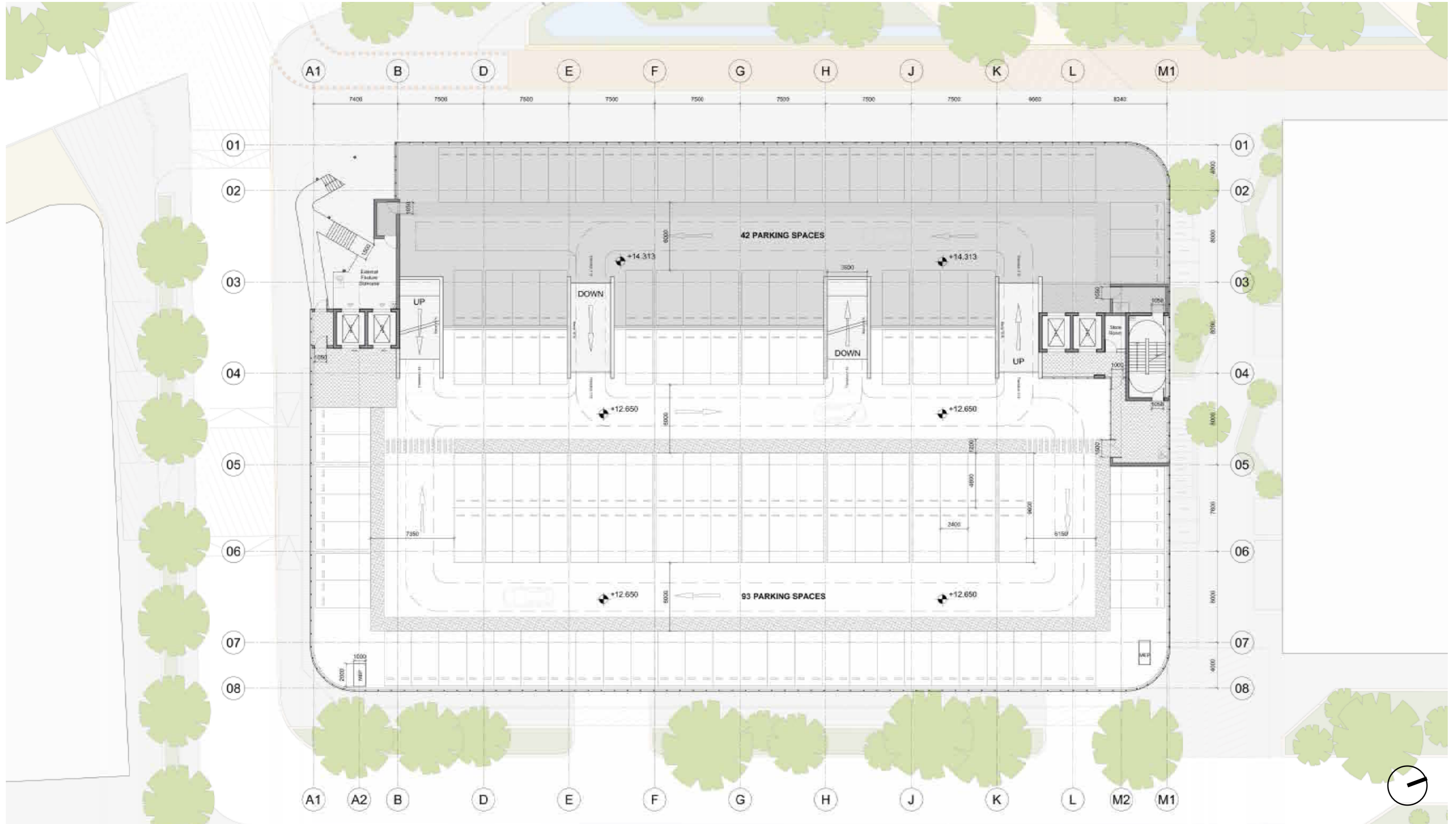

# GENERAL ARRANGEMENT ROOF PLAN

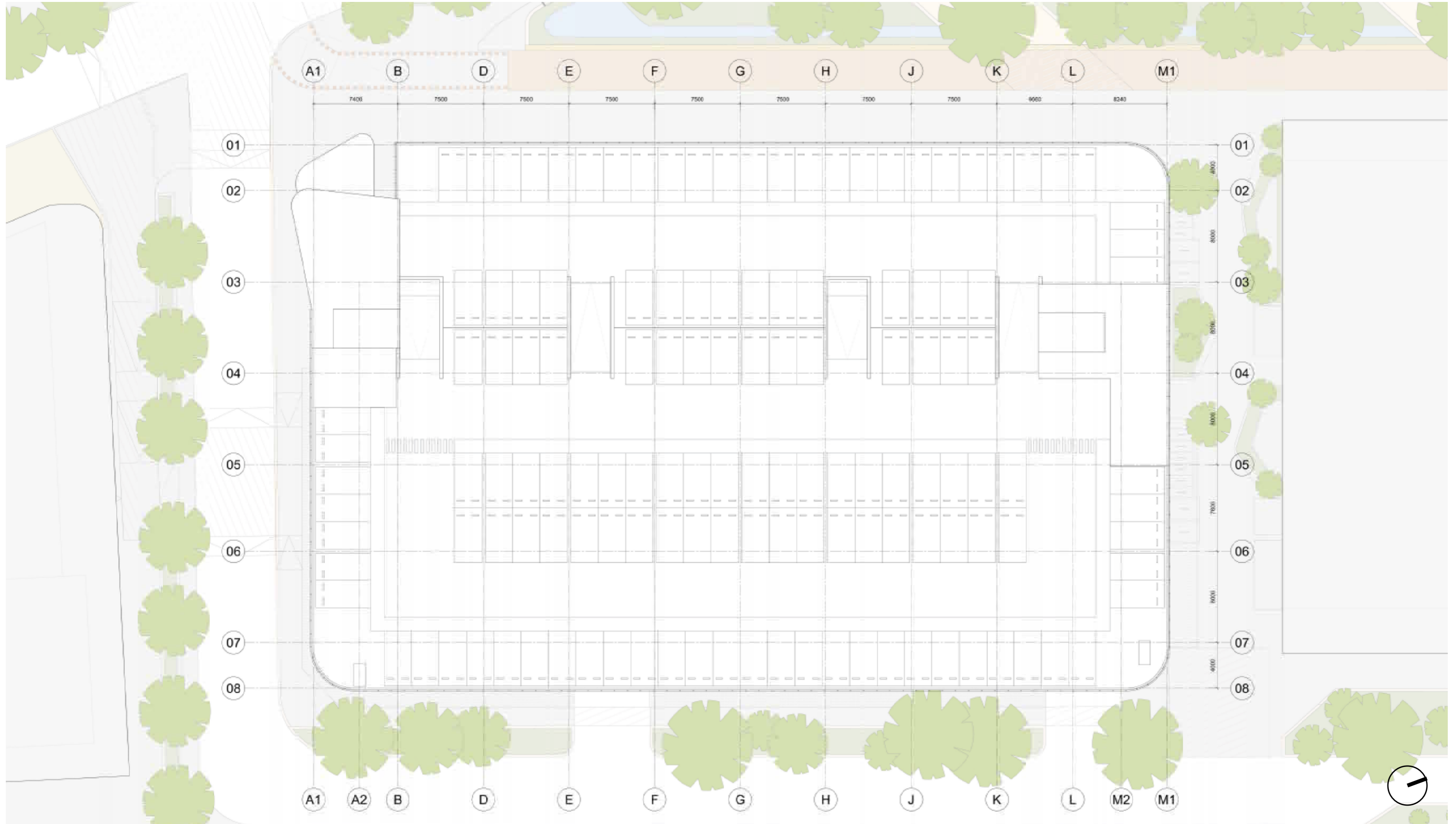

# Building Envelope

# BUILDING ENVELOPE DESIGN PRINCIPLES



## ARTICULATED FACADE TO BREAK DOWN MASSING

Adopt an articulated facade to relieve the flatness of appearance of a typical parking structure and mitigate the length by breaking it down into a more pleasing rhythm, utilising three-dimensionality to create depth and visual interest.

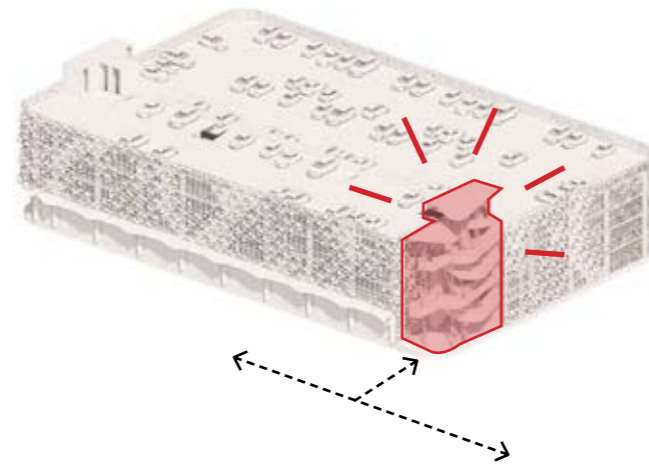

## FEATURE STAIRCASE TO SIGNAL LANDMARK BUILDING

Incorporate a feature staircase at the south-western corner, the intersection of Milton Avenue and Station Row creating a distinct landmark at the gateway to the larger scheme.

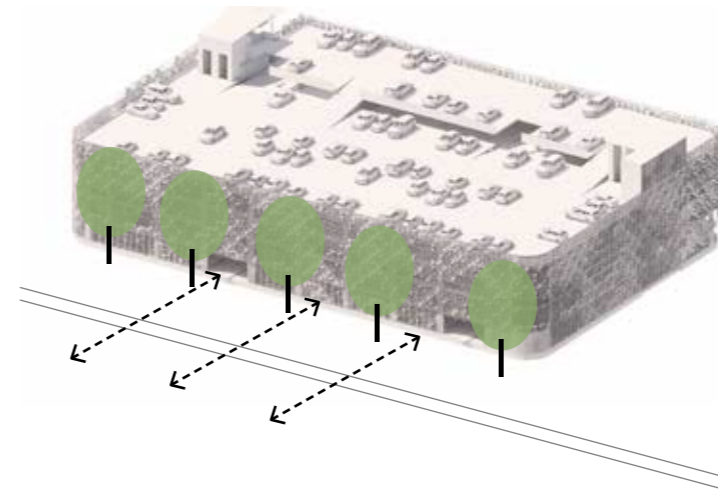

## MATURE TREE PLANTING STRATEGY

Allow for mature trees on the eastern edge to mitigate the impact on long distance views and soften the views of the facade from a distance as well as enhance user experience of Cowley Road.

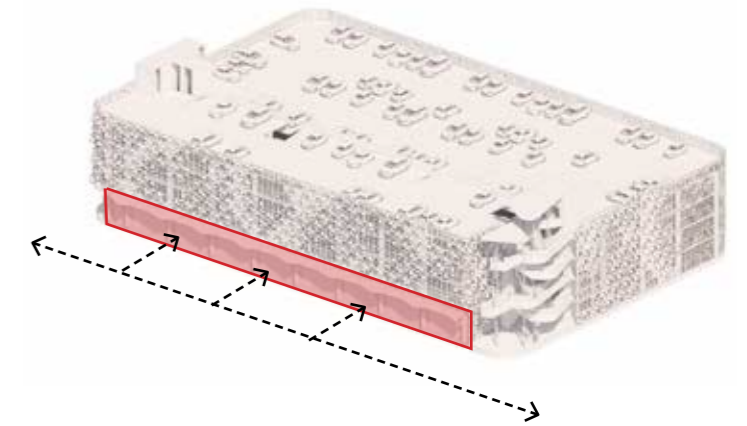

## ACTIVATED GROUND LEVEL ALONG KEY PEDESTRIAN ROUTES

Activate the western facade with retail units at ground level to enhance the pedestrian experience along Station Row.

# BUILDING ENVELOPE DESIGN ELEMENTS

The Mobility Hub has been designed to respond to different contextual conditions and sensitivities across its western and eastern elevations.

## WESTERN ELEVATION

The western facade is a key pedestrian route as it plays a significant part in the arrival of the scheme from the station.

The feature stair at the south western corner of this landmark building signals the gateway leading towards the rest of the development.

This elevation forms one of the main pedestrian flows from the station and has been enhanced by active frontages to enliven the pedestrian experience and avoid the monotonous views of vehicles within the car park.

## EASTERN ELEVATION

Located on Cowley road facing onto the train tracks and the Great Fen area east of the site, this elevation is more concerned with longer distance views.

As the building is visible in part from some key long distance views, the facade will need to be designed to reduce the visual impact of the overall massing.

As an outward facing elevation fronting low lying context, a key consideration for this elevation is light pollution as well.

## Western Elevation

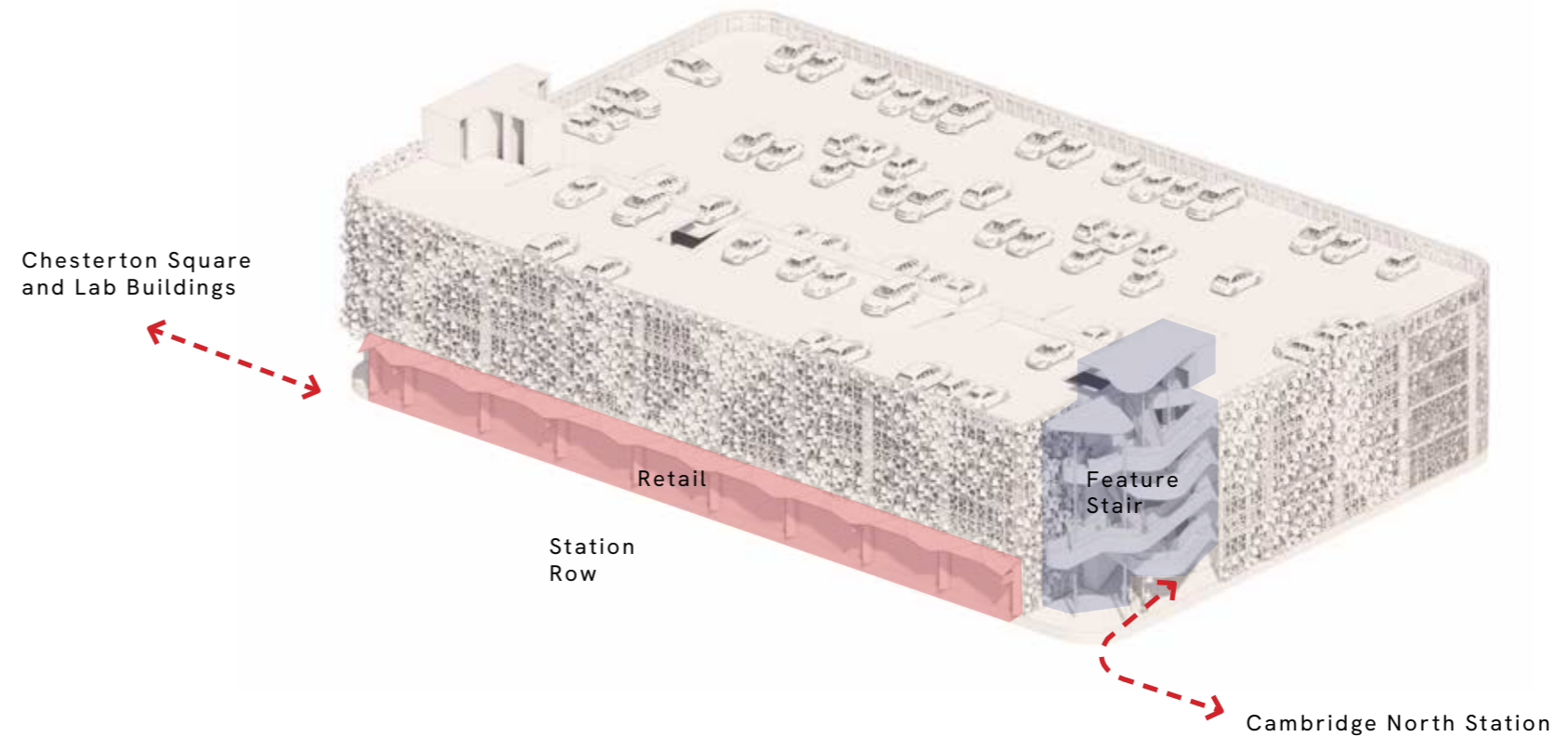

## Eastern Elevation

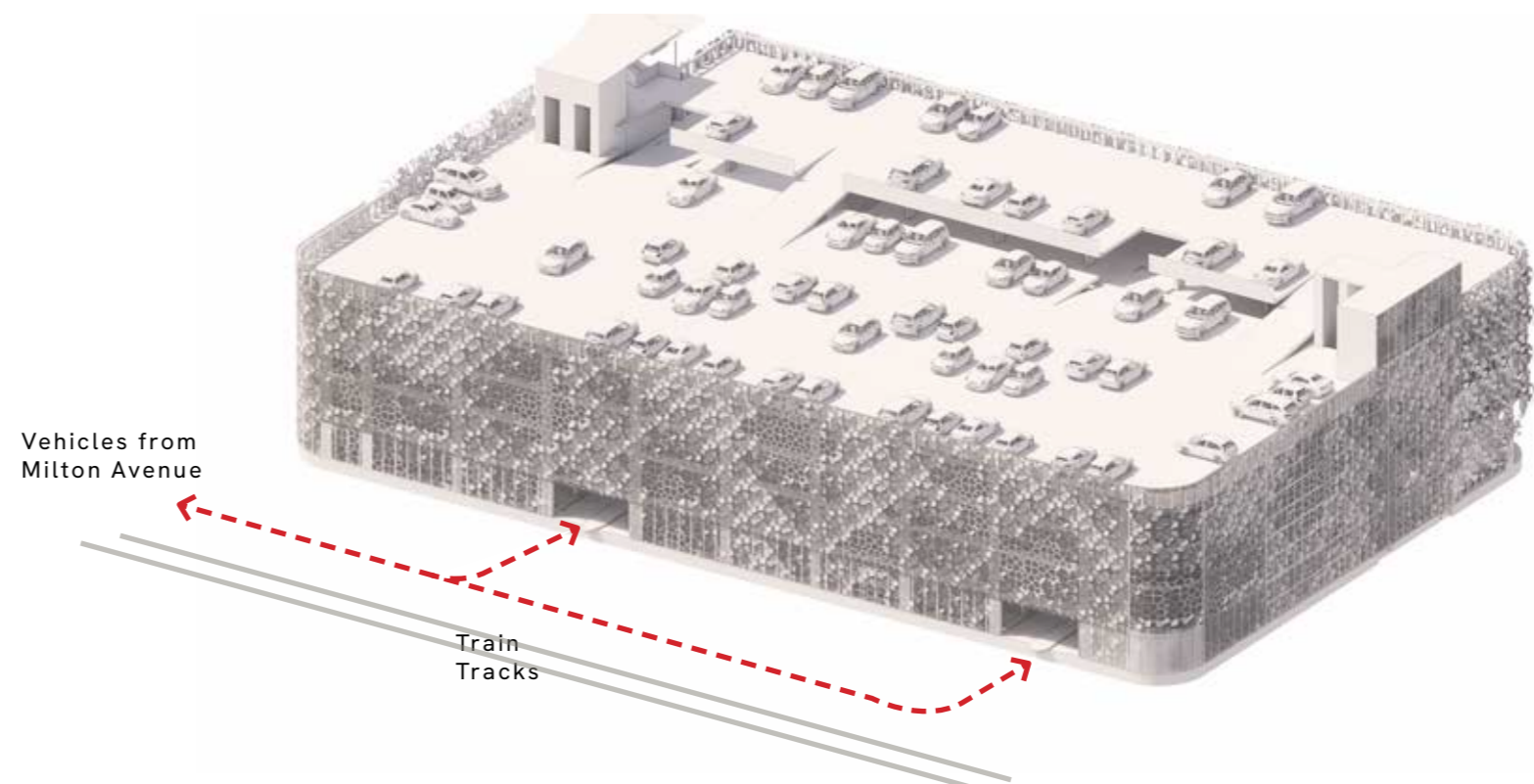

# BUILDING ENVELOPE DESIGN INSPIRATION



## DOROTHY HODGKIN

Dorothy Hodgkin is the first woman from Cambridge to have been awarded a Nobel Prize for her work on the structure of compounds used in fighting anaemia.

Dorothy Mary Crowfoot Hodgkin OM FRS HonFRSC (12 May 1910 – 29 July 1994) was a British chemist who advanced the technique of X-ray crystallography to determine the structure of biomolecules, which became essential for structural biology.

Among her most influential discoveries are the confirmation of the structure of penicillin as previously surmised by Edward Abraham and Ernst Boris Chain; and the structure of vitamin B12, for which in 1964 she became the third woman to win the Nobel Prize in Chemistry. Hodgkin also elucidated the structure of insulin in 1969 after 35 years of work.

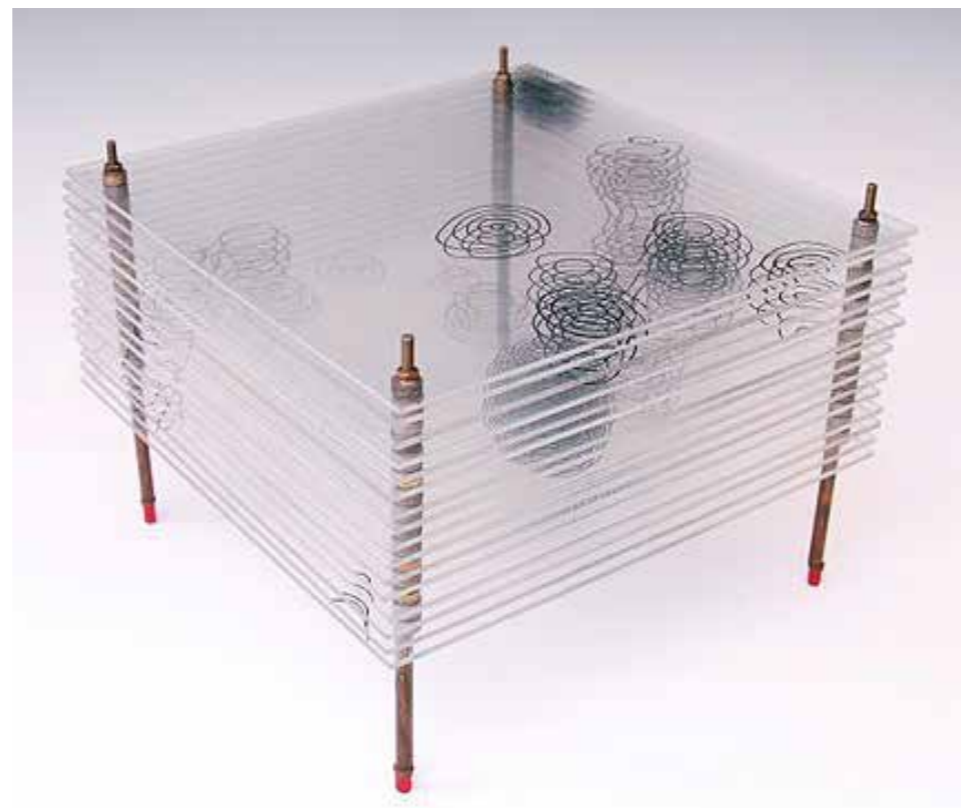
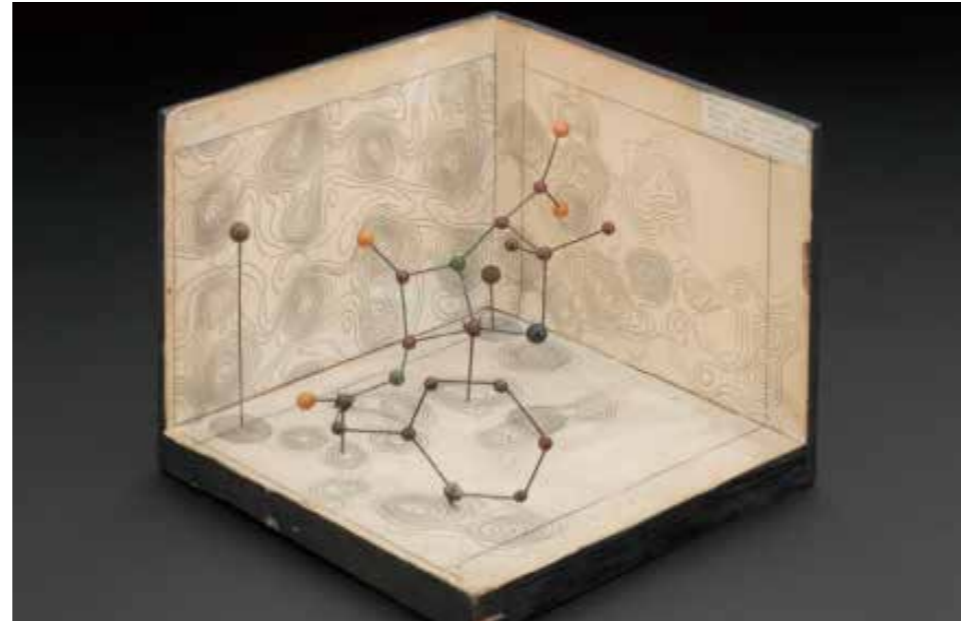

Electron Mapping Scientific Models

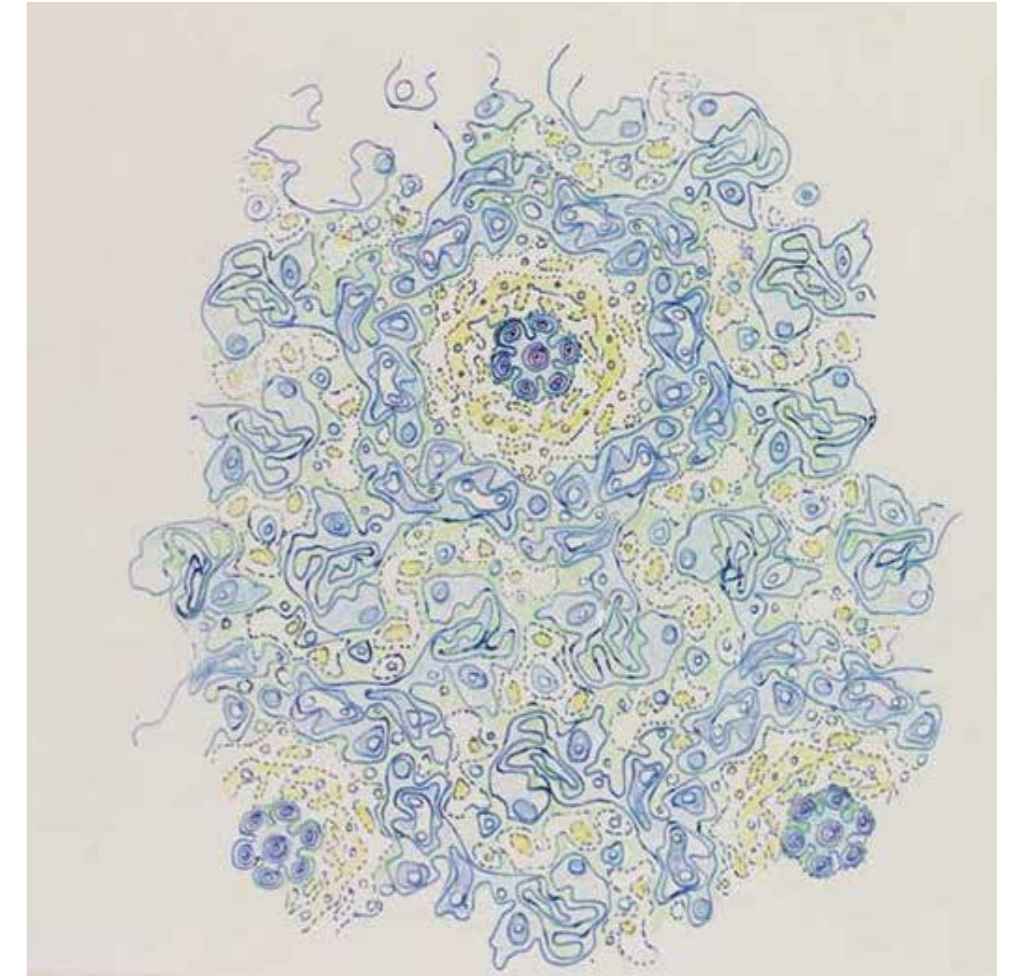

Insulin Structure Illustration

# BUILDING ENVELOPE FACADE CONCEPT

## CRYSTALLOGRAPHY

X-ray crystallography is the science determining the atomic and molecular structure of a crystal. By measuring the angles and intensities of diffracted beams passed through the crystal, a crystallographer can produce a three-dimensional picture of the density of electrons within the crystal. From this electron density, the mean positions of the atoms in the crystal can be determined, as well as their chemical bonds, their crystallographic disorder, and various other information.

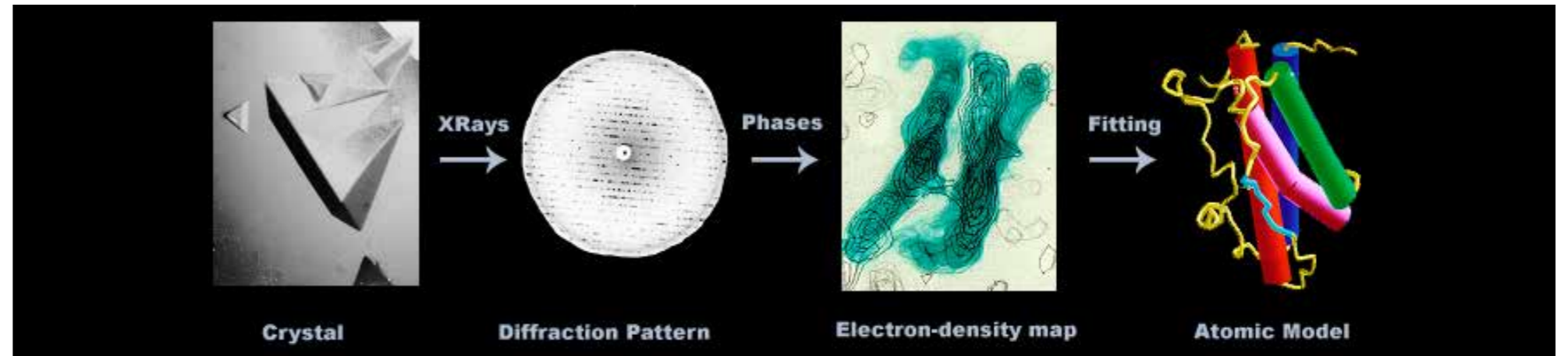

Outline of crystallography process

## MOBILITY HUB FACADE

The facade is conceptualised as an interplay of scales, mirroring the process of crystallography. From a distance, the facade conveys the pattern of that of the electron maps, with its organic concentric forms, up close however, one is then able to identify the base module that forms this pattern. Acme has chosen the base structure of the vitamin B12 molecule, part of the Nobel prize winning work of Dorothy Hodgkin as inspiration for our facade design. This mirrors the process from which the molecular structures of proteins are derived from a much broader pattern created through the electron density mapping.

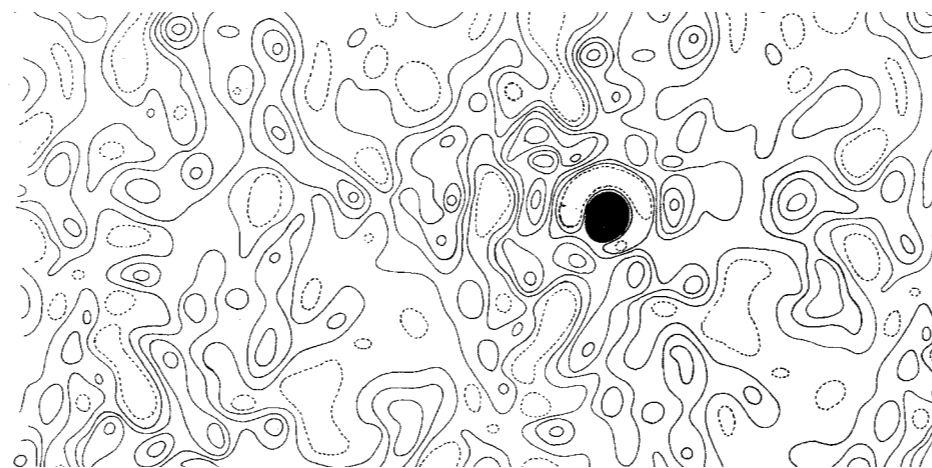

Electron density map

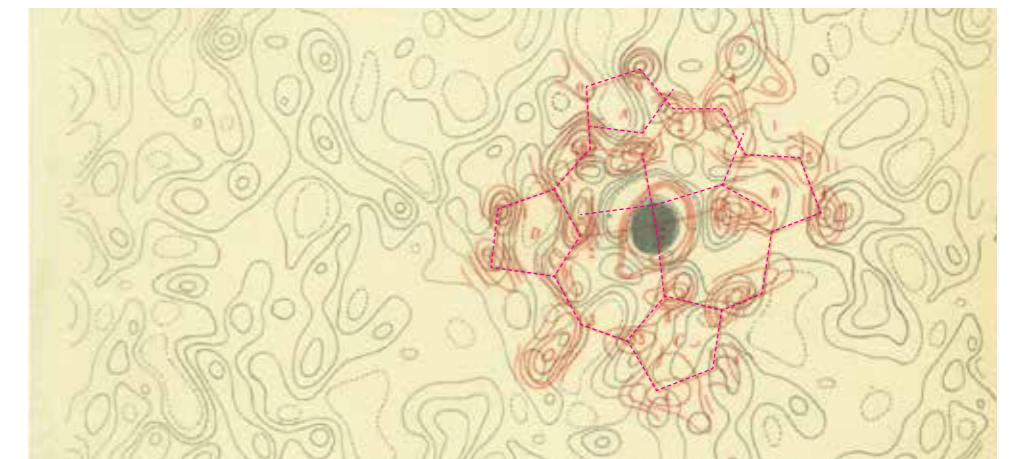

Structure determination



Electron mapping pattern seen from a distance



Protein base structure from up-close



# BUILDING ENVELOPE FACADE TYPES

To address the specific needs of the western and eastern elevations, the Mobility Hub will feature two facade types.

## FOLDED METAL PANELS

The first type of facade is made out of folded metal panels. This consists of laser cut aluminium panels that are cut and bent at different angles in order to derive a discernible pattern from afar. The finish consists of a PPC coating for colour and longevity.

## PERFORATED METAL PANELS

As light pollution is one of the main consideration for the eastern facade, a perforated metal panel system has been adopted here to reduce the potential for light pollution in combination with raised crash barriers as set out further in this chapter. The perforation pattern is to be derived from the western facade pattern to maintain contiguity.

Legend:

■ Type 1 - Folded Metal Panel

■ Type 2 - Perforated Metal Panel

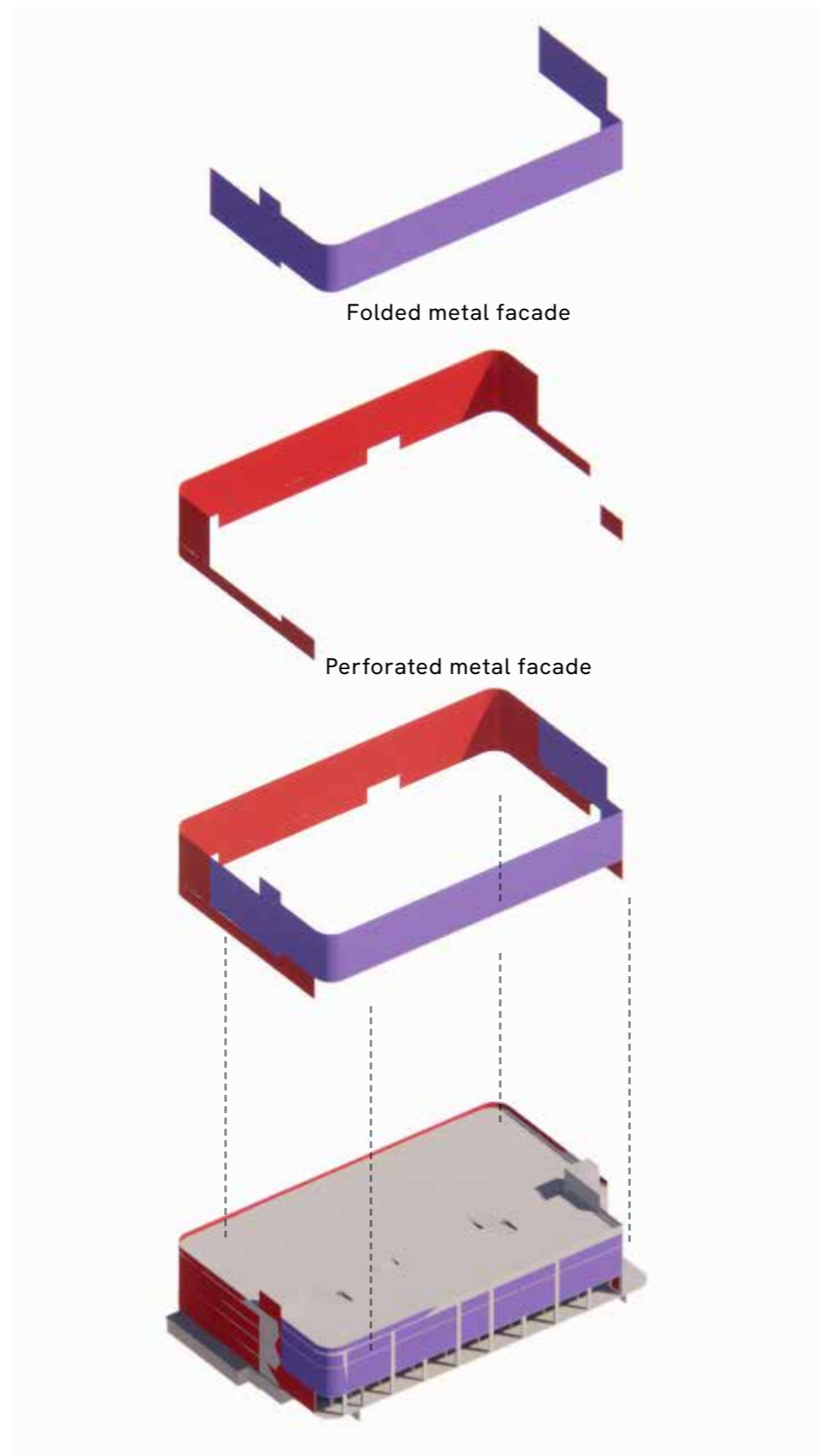

Facade Type Distribution



Folded metal facade

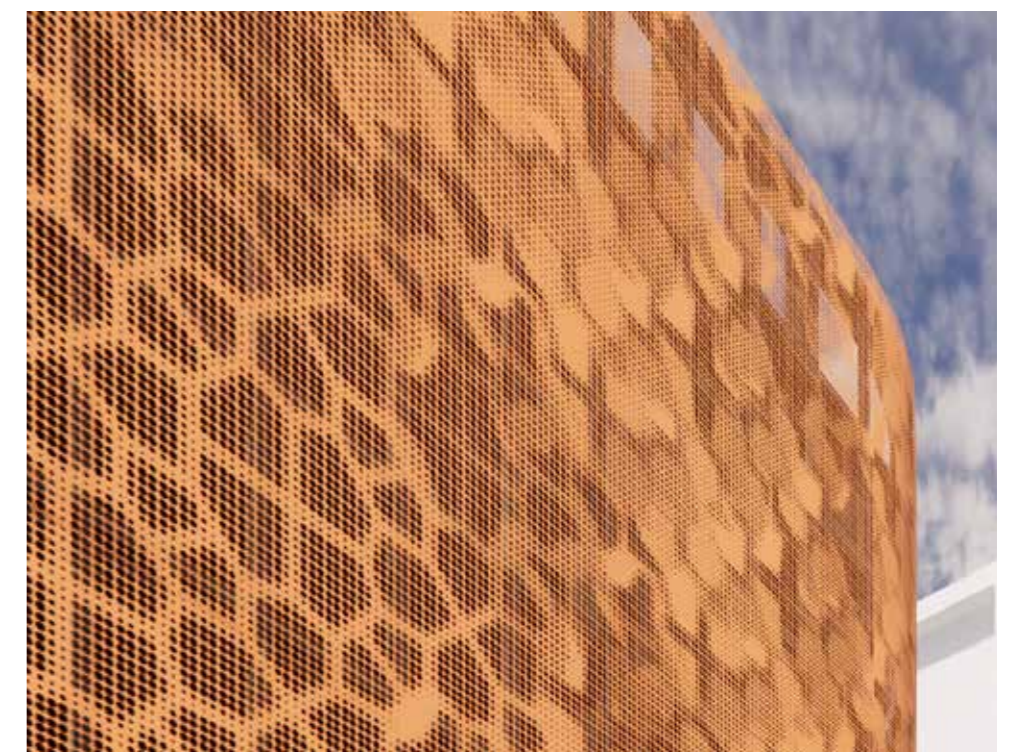

Perforated metal facade

# BUILDING ENVELOPE

## WESTERN FACADE MATERIALITY / FOLDED PETALS

This western facade consists of laser cut aluminium panels that are cut and bent at different angles in order to derive a discernible pattern from afar.

The process allows us to achieve maximum depth and texture from an otherwise flat material.

The aluminium panels are to be powder coated to allow for durability and ease of maintenance.

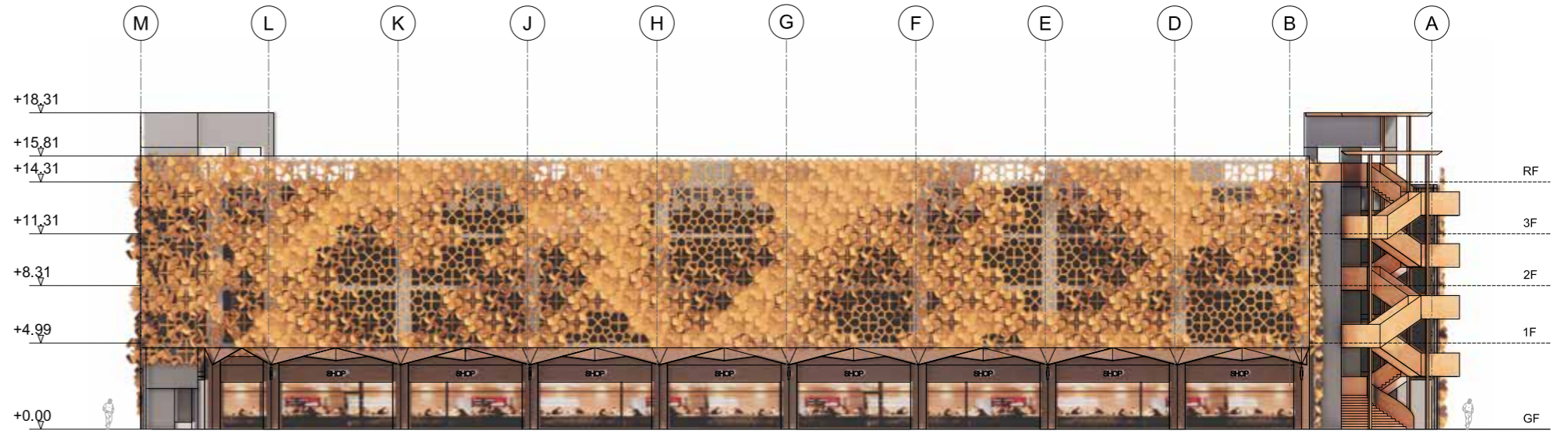

Western elevation

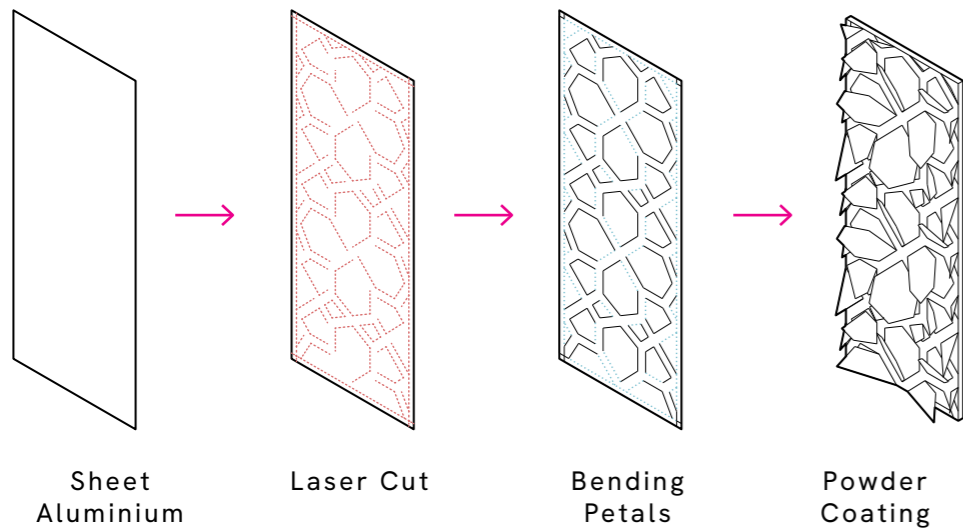

Fabrication Process

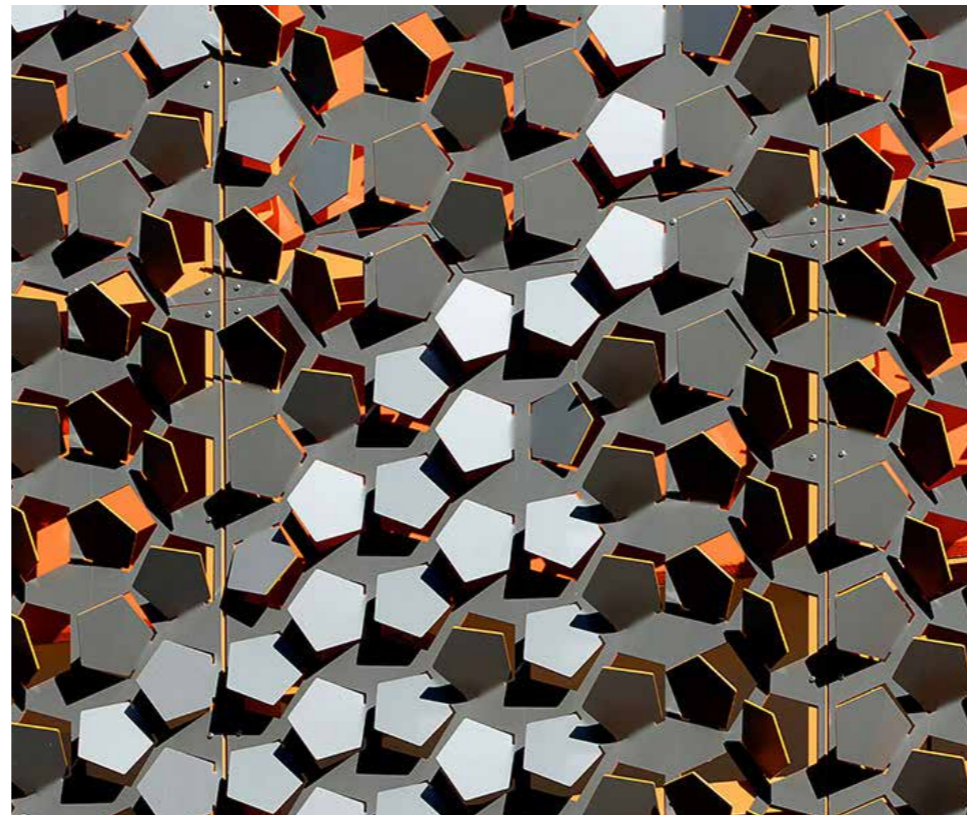

Robina Carpark, Australia



# BUILDING ENVELOPE DESIGN EVOLUTION OF WESTERN FACADE

The early iterations of the western facade begun with the exploration of mesh wrapped planters. The metal mesh was intended to be fixed across the planters to create a sculptural facade that would then allow vegetation to grow across it greening the facade. This was not pursued further due to concerns of the long term maintenance of the plants.

Other options explored using intersecting metal fins to mimic the patterns and drawings of electron mapping. The main concern associated with this option was the feasibility of construction with regards to creating a unique pattern across the entire facade, modularisation could have been used, but it was felt that the pattern to be read across the building would need to be of a scale large enough to help break down the massing and if the patterns were reduced to modules it would look overly repetitive.

The final design for the facade treatment was the option of the folded metal petals, ACME felt that this was the most suitable treatment as it allows for interesting textures to be experienced at different scales and distances whilst allowing for modularisation. It also has strong conceptual links to Cambridge with its homage to the first female Nobel Prize winner, and hence was the option that was selected.



Mesh wrapped planters



Intersecting fins



Folded metal petals



# BUILDING ENVELOPE FACADE MODULARISATION

The facade module is a pattern derived from the base structure of vitamin B12, utilising the base geometry. We have looked into varying panel modularisation options to rationalise the pattern and building process.

Facade consultants have assessed the concept to ensure the deliverability of the facade. The substructure is to be physically mounted on the slab and column edges of the building, onto which the modules would be hung and attached to.

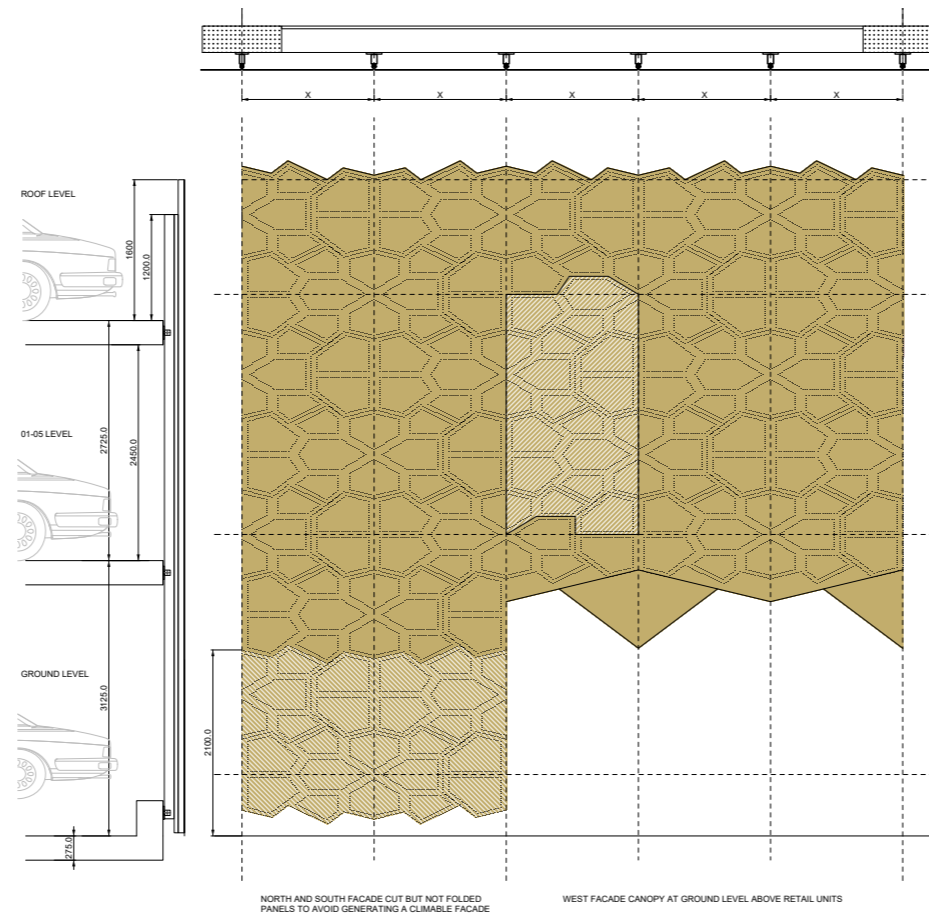

Elevation detail

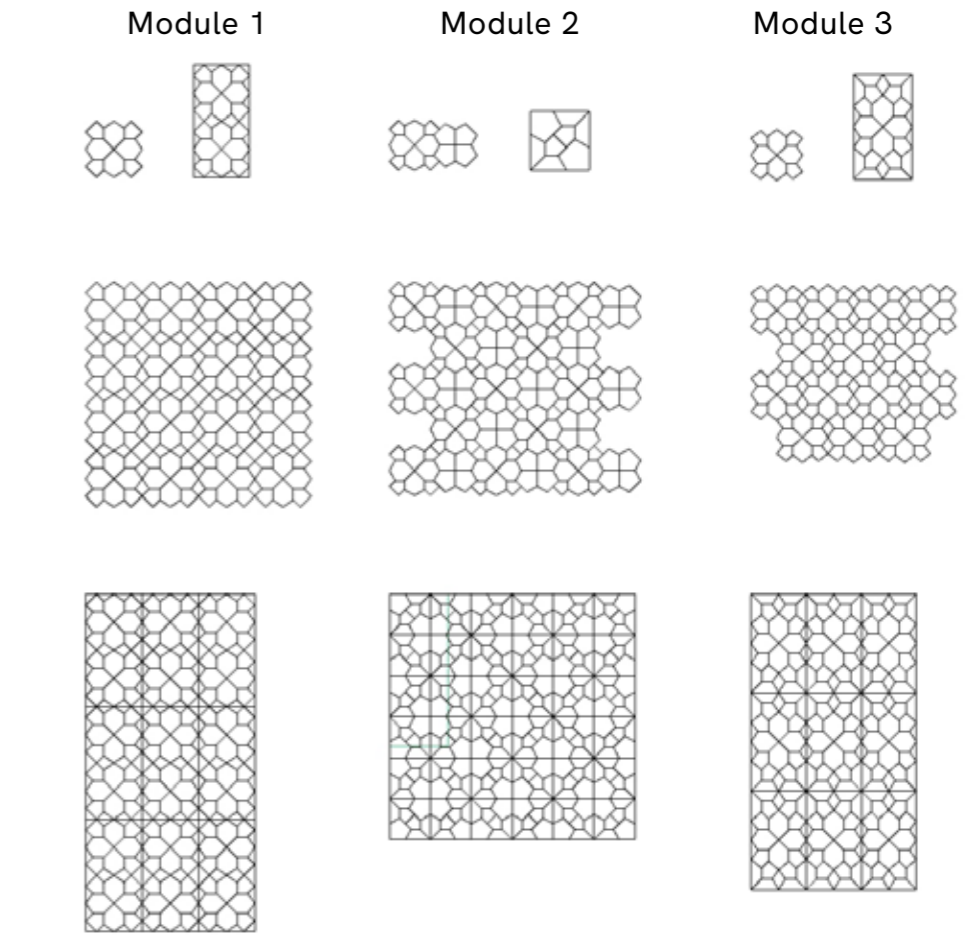

Modularisation Study

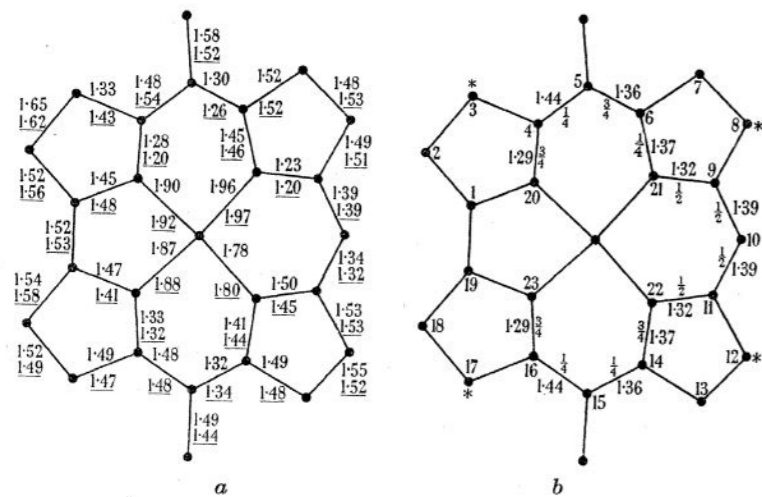

Vitamin B12 Base Structure

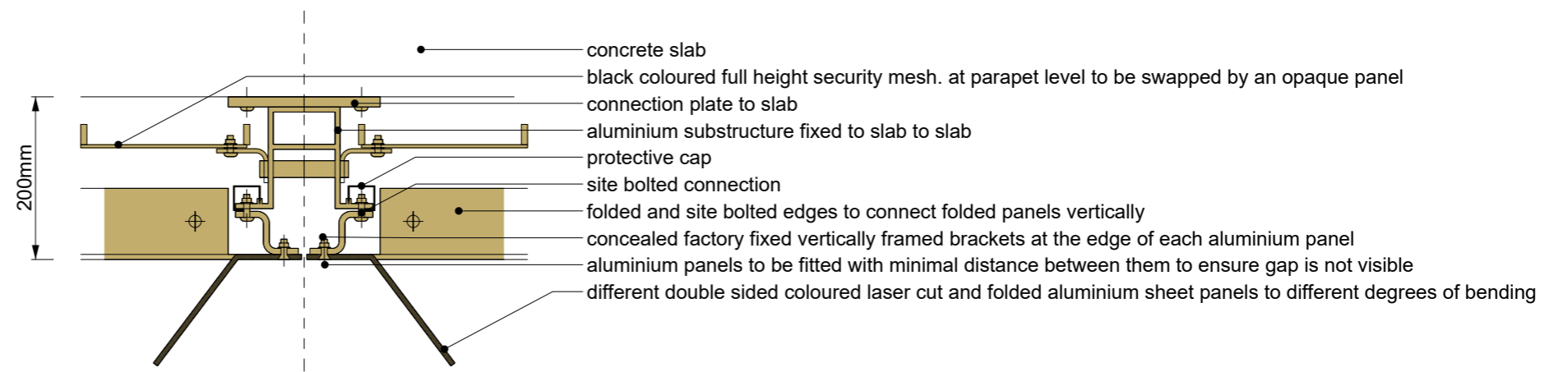

Illustrative detail of horizontal section showing fixings

# ILLUSTRATIVE VIEW



View down Station Row seen from front of the feature staircase

# BUILDING ENVELOPE

## EASTERN FACADE MATERIALITY/ PERFORATED PANELS

### PERFORATION

As the eastern facade requires more sensitivity for light pollution, the folded metal facade is not used here as the large apertures would allow too much light to pass.

Instead, this facade uses perforated panels to mimic the treatment of the eastern facade. This achieves the benefit of maintaining a consistent aesthetic theme across all facades of the building whilst allowing for greater mitigation to light pollution where needed.

The use of perforations to generate patterns that can be viewed from a long distance can be seen across several precedent reference projects.

The use of the panels has the added benefit of ensuring the safety of the NR rail tracks and that no users can throw anything from within the carpark onto the tracks.

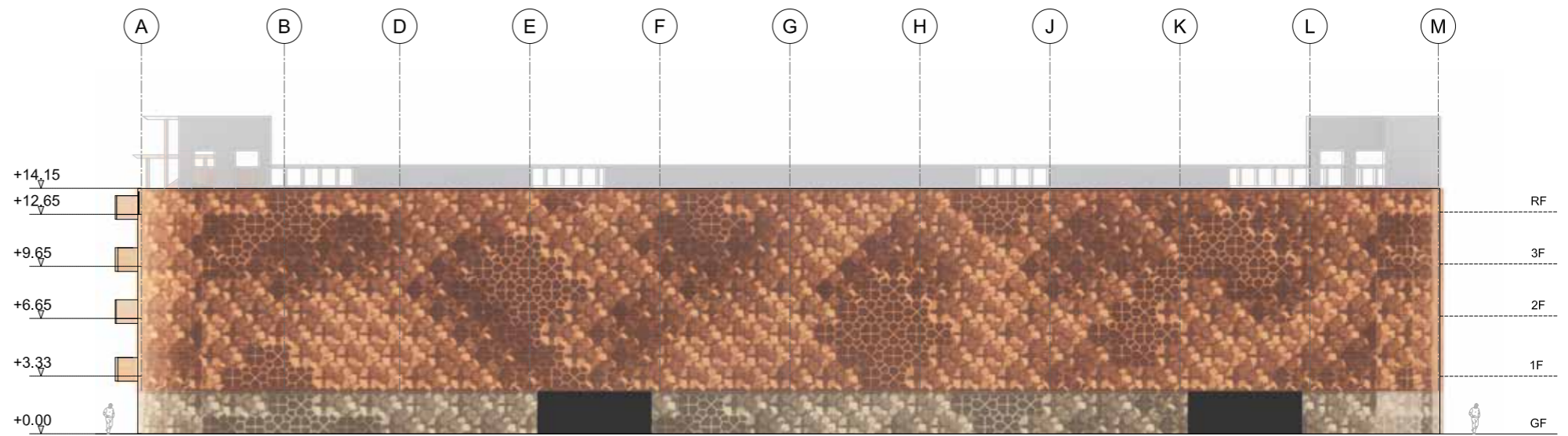

Eastern elevation



Mountain Dwelling carpark facade, Copenhagen



# BUILDING ENVELOPE

## EASTERN FACADE DESIGN EVOLUTION

As for the eastern Facade, the initial idea was to utilise external planters to create as much of a “green wall” as possible. This was to allow for mitigation in the long distance views by breaking up the massing with clumps of vegetation. The intention was to break up the massing in the long distance views by a varied pattern of concentrated green vegetation.

On further consideration, the carpark was shifted west to allow more room along Cowley road for fully mature trees to be planted. This rendered the use of the planters less effective, and due to concerns regarding the long term maintenance of the plants, it was decided to use alternative facade treatments.

Other consideration was given to the folded metal facade extended onto this facade as well. However, due to concerns of light pollution and security of the rail tracks this was not pursued.

Ultimately, it was then decided that utilising perforated panels with a bespoke pattern mimicking the pattern of the western facade would be the optimum solution.



Expanded metal mesh with external planters



Folded metal facade



Folded metal facade



# BUILDING ENVELOPE PERFORATED FACADE PATTERN

## PERFORATION PATTERN GENERATION

The perforation pattern for the eastern facade is generated from the western facade design.

By varying the size and concentration of the perforations, an optical illusion of 3D dimensionality mimicking that of the western facade can be achieved, allowing the facade to mitigate light pollution and enhance NR Rail track security whilst maintaining a common design language.

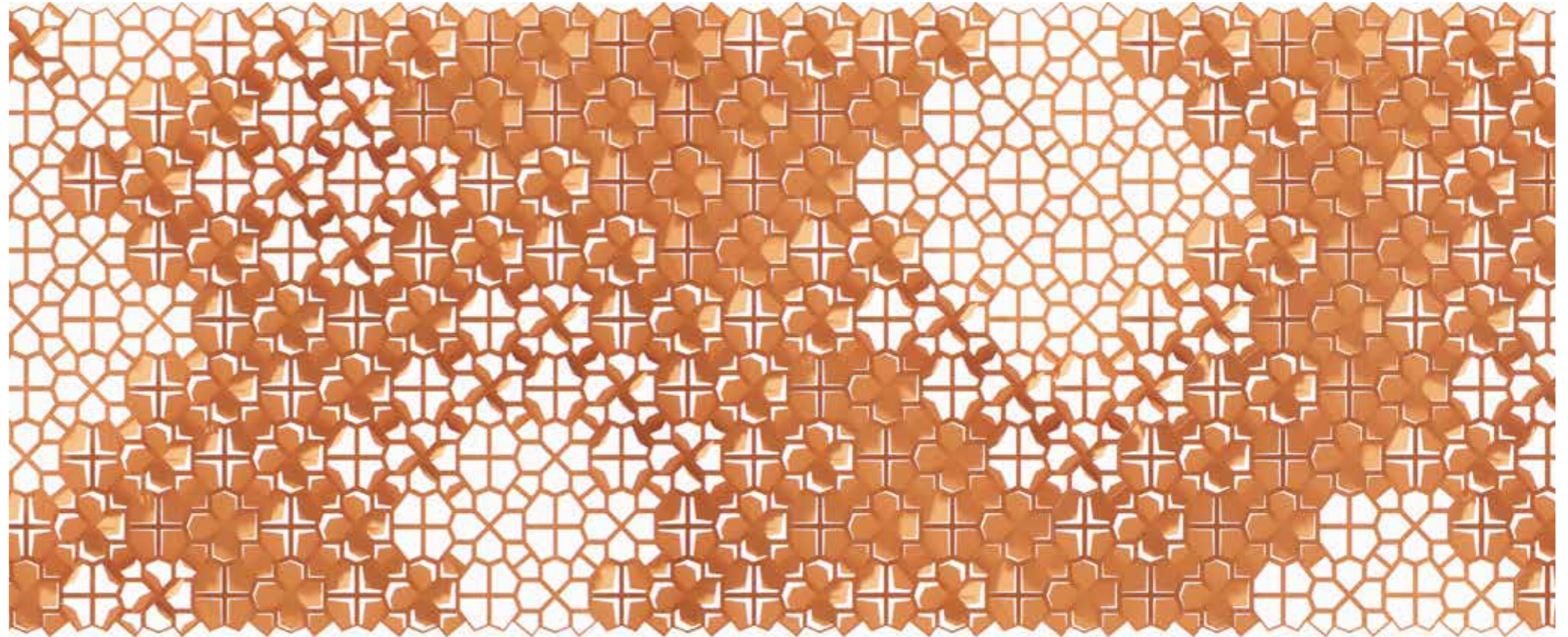

Western facade render

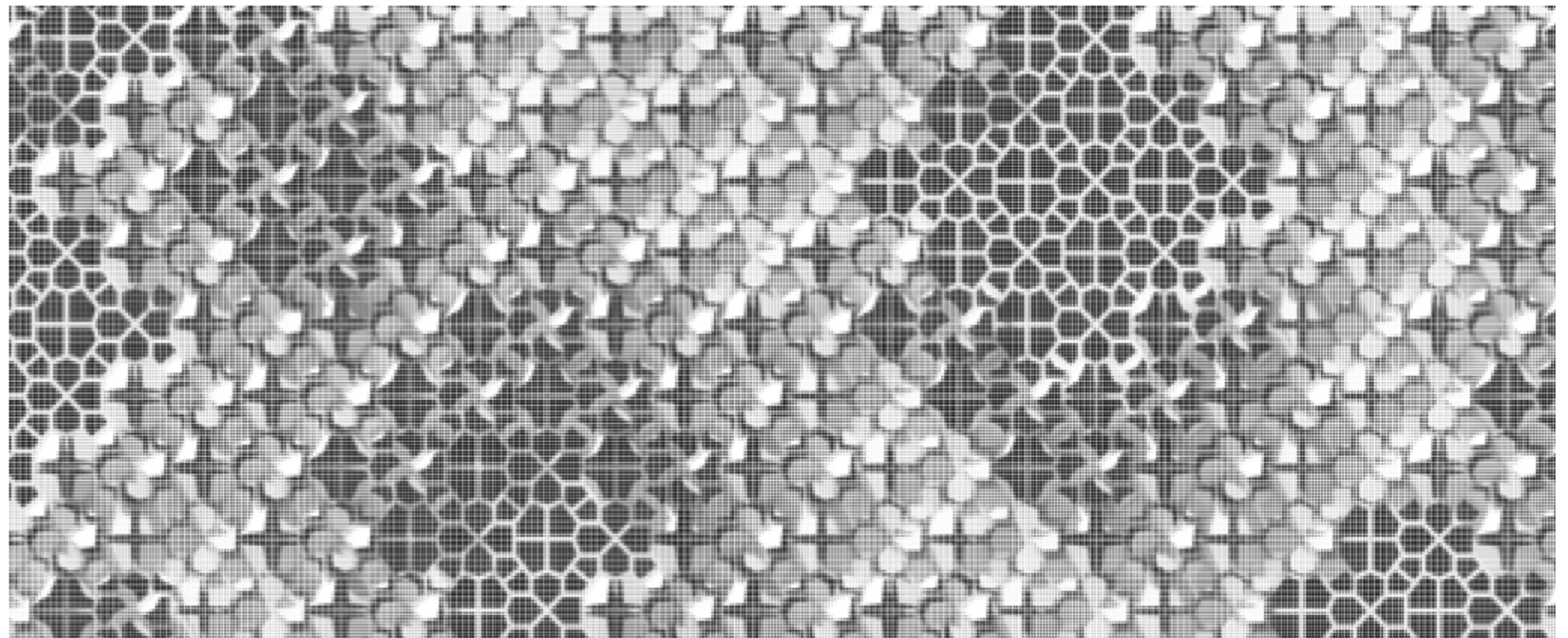

Perforation Pattern

# ILLUSTRATIVE VIEW



View looking south along Cowley Road along the eastern edge

# Feature Staircase

# FEATURE STAIRCASE

## FEATURE STAIRCASE MATERIALITY

### CORTEN STEEL

The feature stair will be made out of corten steel. The choice of material is due to its ease of maintenance and its rich warm colour tones.

The material is strong and durable and has great textural character which will give the feature staircase an added layer of complexity.

The steel also is also a nod to the existing industrial heritage, paying tribute to the material palette of the historic train sidings located on the site.



Precedent Corten Steel Staircase - Landmark Rusty Nail by Stefan Giers in Germany

# BUILDING ENVELOPE FEATURE STAIRCASE DESIGN PRINCIPLES

## MODULAR

Created utilising a triangular module of stairs that is staggered frontwards and backwards, giving the staircase a dynamic and fluid appearance whilst maintaining reasonable travel distances.

## EXTERNAL STAIR

The staircase is a fully external stair, designed such that the routes are generous, but not have too many open landings to discourage loitering.

Shelter has been provided at roof level and each flight creates shelter to the one below.

Stair Circulation

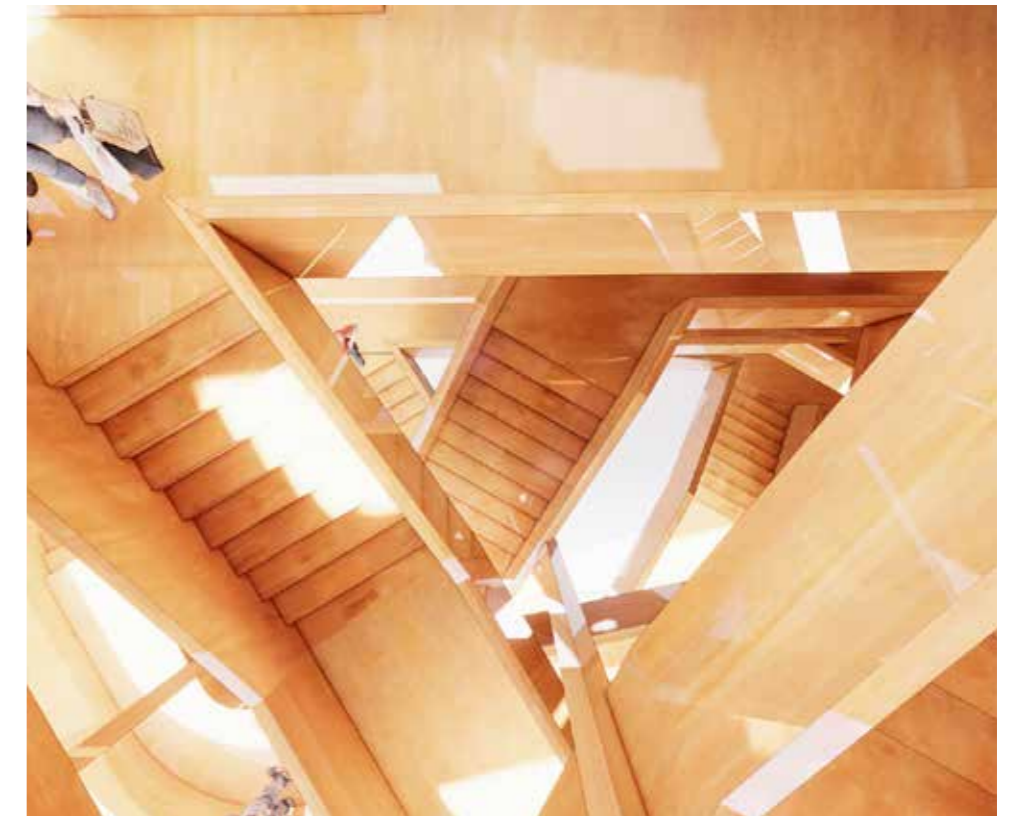
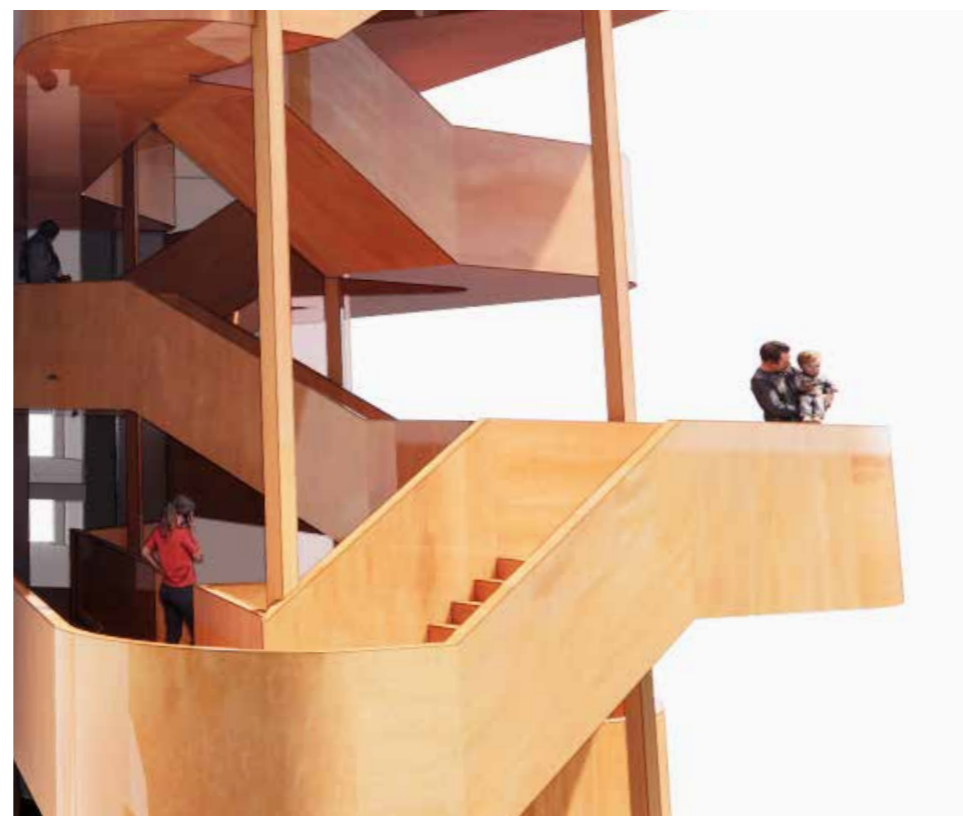
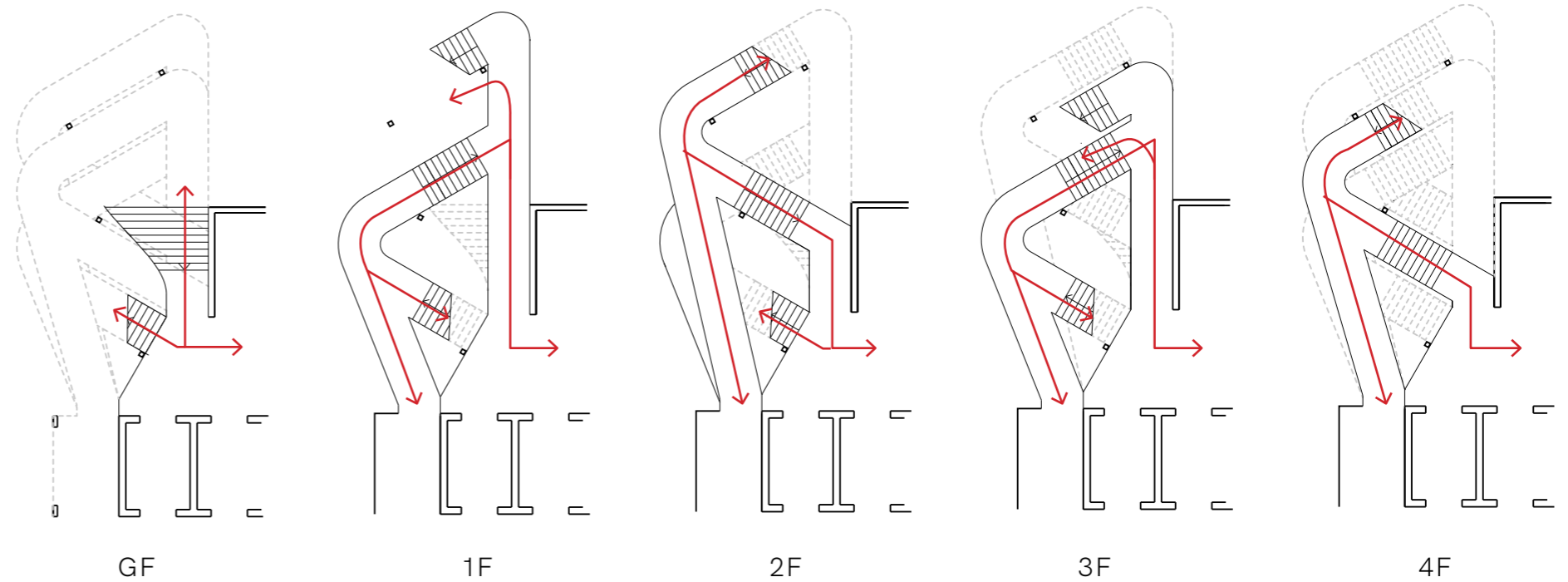

Stair experience

# ILLUSTRATIVE VIEW



View along the Mobility Hub looking north

# Working Strategies

# MOBILITY HUB ACCESS AND CIRCULATION

## PEDESTRIAN CIRCULATION

All lifts within the building are 2 sided and operate between every level and half level to service all floors of the Mobility Hub.

In the south western corner of the building, there is a feature staircase to encourage the use of the stairs to reduce lift utilisation and enhance the user experience of the building.

The level difference across the split decks are mediated by the vertical circulation stairs, opening out on every landing to access all floors.

Pedestrian walkways and crossings throughout the floor plate are optimised to reduce the number of intersections between pedestrian and vehicular routes. These routes will be clearly demarcated to provide visual distinction.

## VEHICLE CIRCULATION

Vehicle entry into the building is located at ground floor level on the eastern edge of the building facing the tracks.

Vehicle circulation across the decks is accessed by 4 ramps, with targeted single direction traffic flows. The outer loop of ramps allow for upward circulation, while the inner loop of ramps is dedicated to downward circulation. This minimises travel distances for exiting the building.

Basement level pedestrian circulation

Ground floor pedestrian circulation

Typical floor pedestrian circulation

CAMBRIDGE NORTH - BROOKGATE LAND LIMITED

323

DESIGN AND ACCESS STATEMENT | JUNE 2022



# MOBILITY HUB ACCESSIBILITY STRATEGY

Blue badge parking spaces are designed with surrounding clearance on 3 sides, allowing for maximum ease of access.

All blue badge parking are located at ground level so as to minimise travel distances for its users.

Accessibility for other user groups has been considered with tactile flooring incorporated where needed to aid the visually impaired.



Blue badge parking



Tactile paving

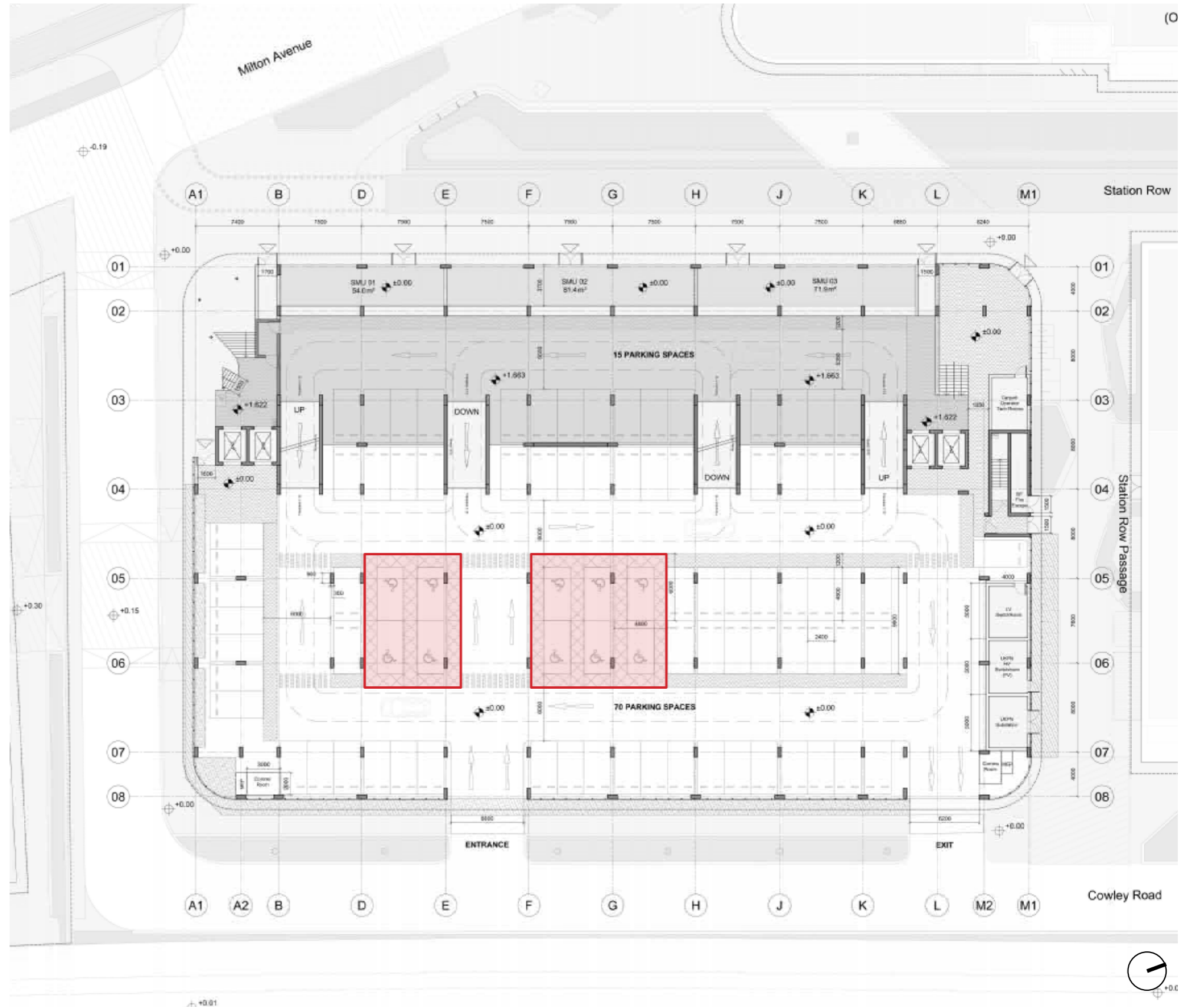

Ground floor plan

# MOBILITY HUB GROUND FLOOR ACTIVATION

At ground level, the western edge has been activated with a number of retail units facing Station Row.

The tenants of the retail units will be curated with the aim to target outstanding small and local business and provide a uniquely local provision for the surrounding areas.

The mix of retail will also be considered to have at least one bicycle shop so that the Mobility Hub can function to support alternative forms of transportation within the scheme in line with its sustainability goals.



F&B outlets



Bicycle repair shop

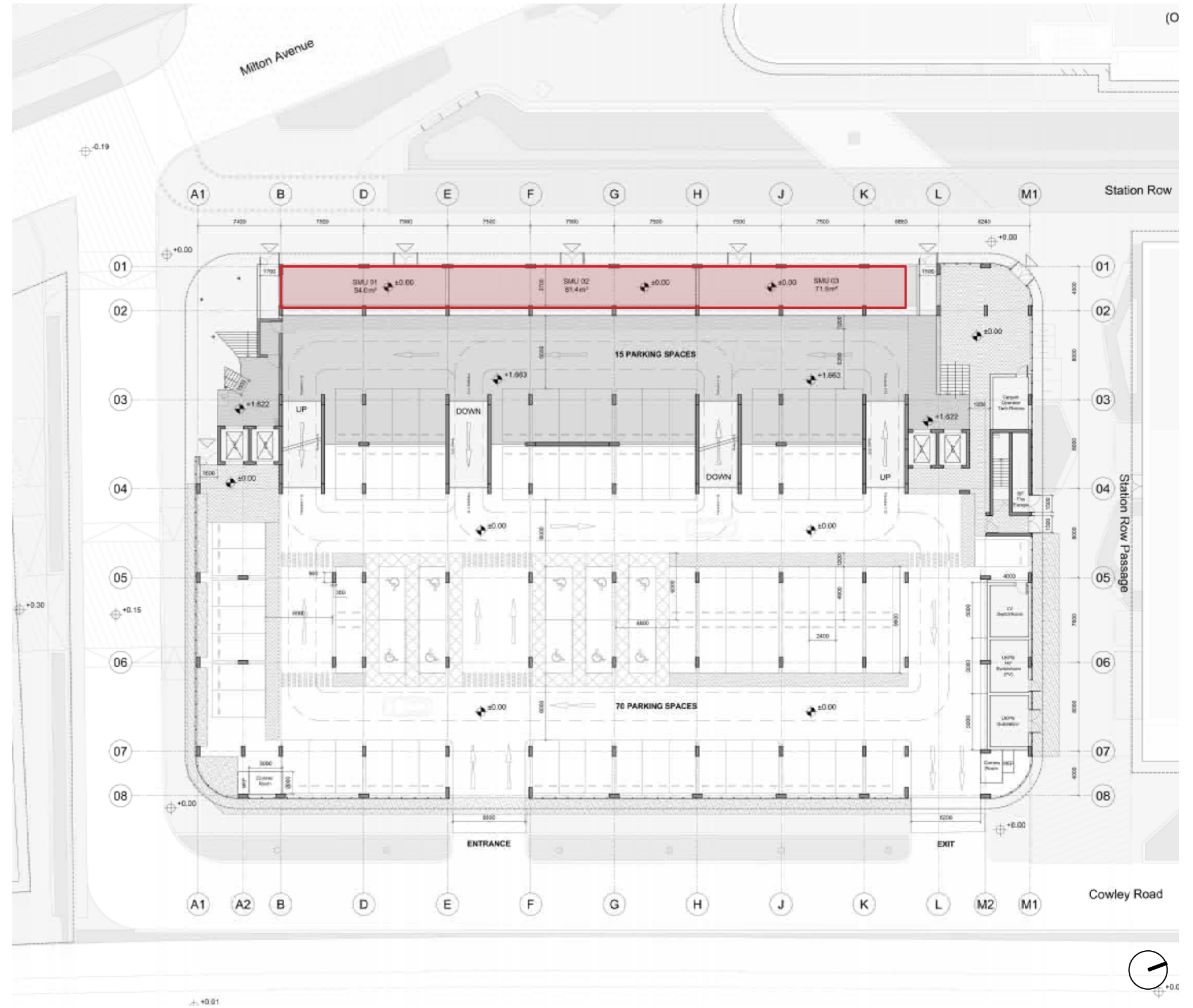

Ground floor plan

# MOBILITY HUB CORES, LIFTS & FIRE ESCAPES

## CORES

All fire escape stairs for the building are to be external staircases that are naturally lit and ventilated.

Where needed fire lobbies are placed assuming fire doors are recessed and hidden by aligning flush with interior walls. Fire doors are to be held open by magnetic door holders that will release upon triggering of fire alarm, allowing for functional use of fire lobbies while minimising disruption for the day to day circulation routes.

## FIRE ESCAPE ROUTES

As there are 2 cores and hence 2 means of escape, fire escape distances are compliant with building regulations, with at least one means of escape being kept to less than 45m up to the fire lobby across each floor.

*Please refer to Fire Safety Statement by Hilson Moran for full assessment report.*

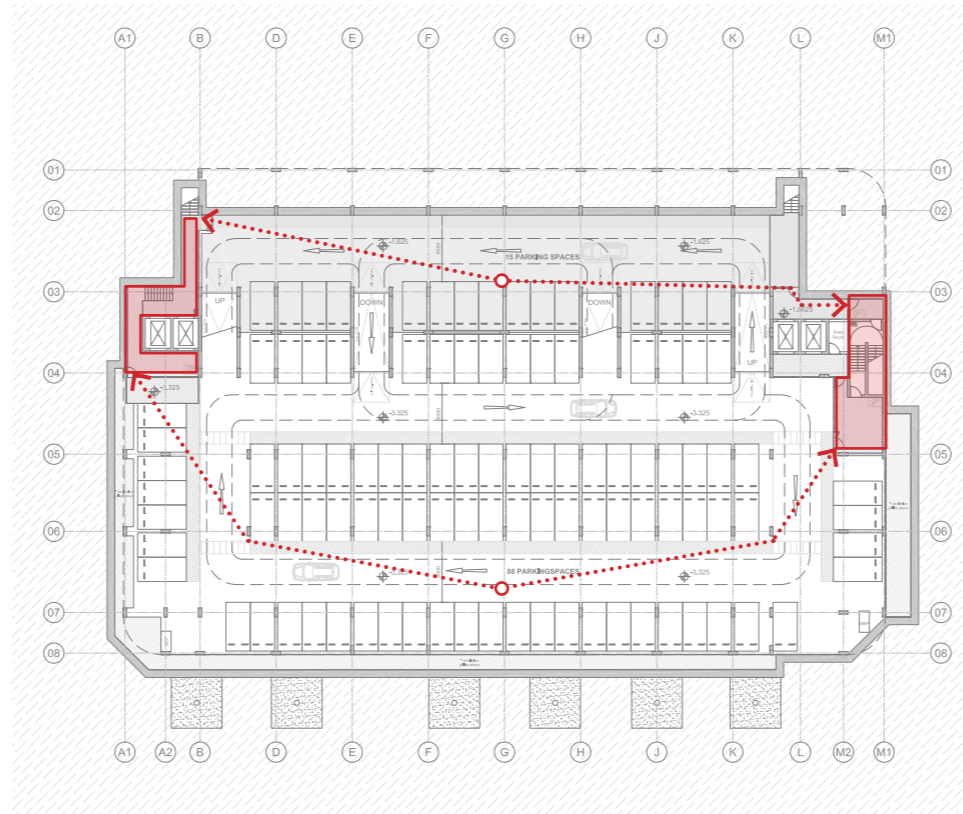

BF Fire Escape Route

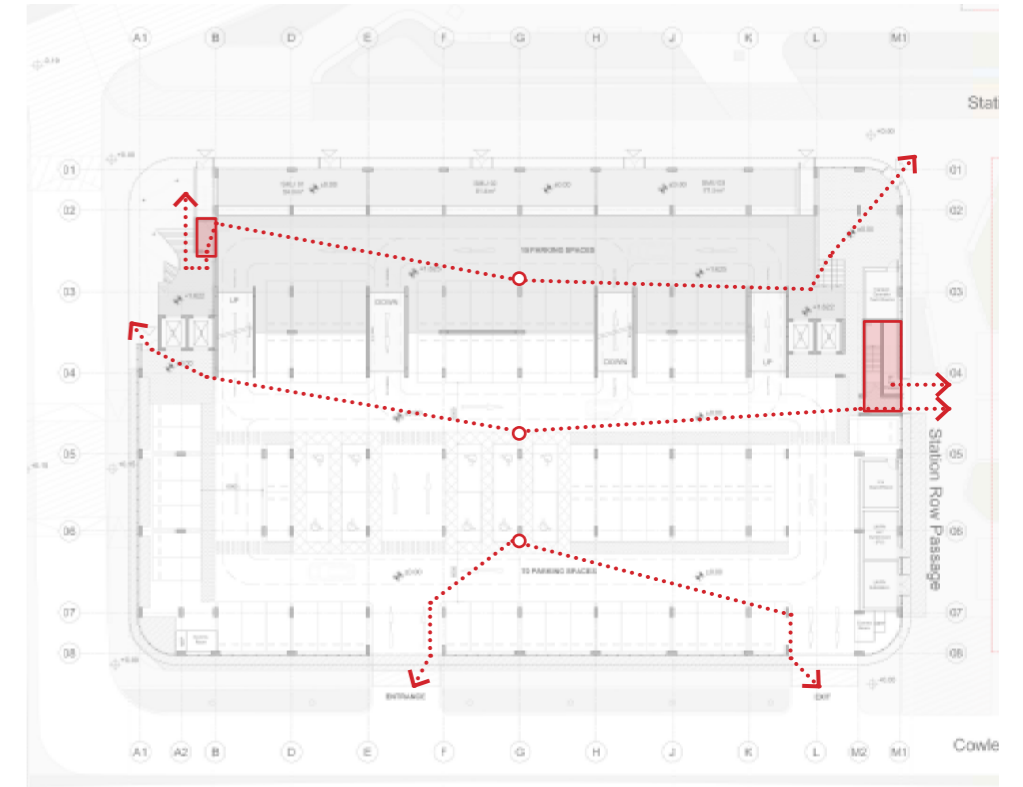

GF Fire Escape Route

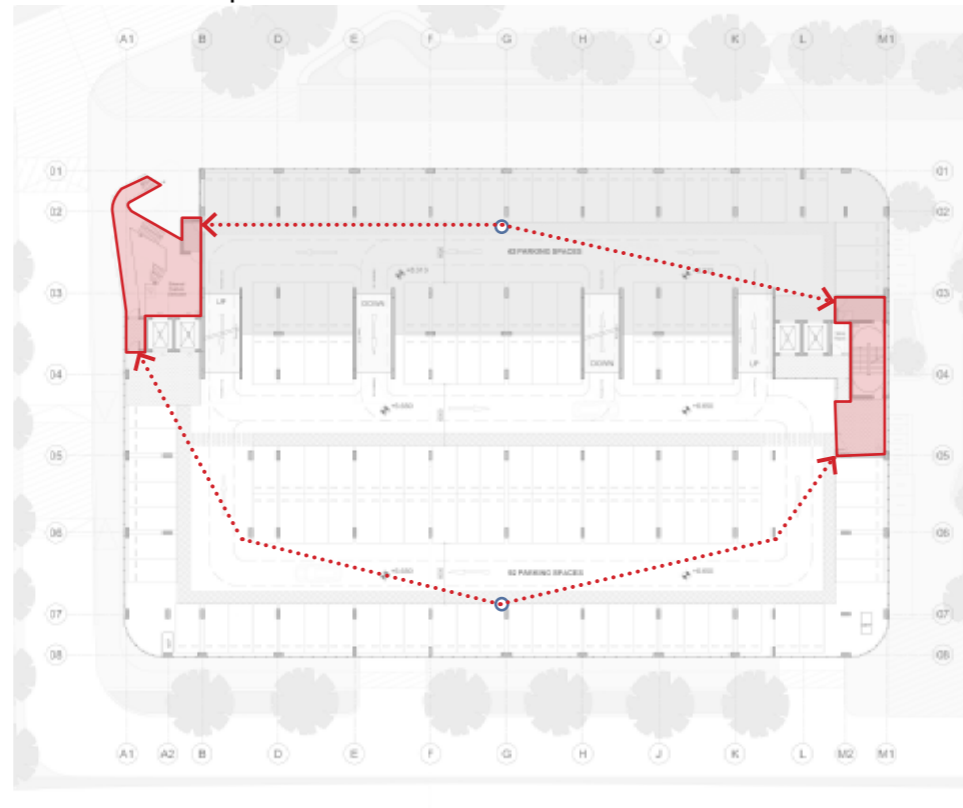

Typical Floor Fire Escape Route

# MOBILITY HUB LIGHTING

The lighting strategy for the Mobility Hub has been carefully considered to create a safe environment in which adequate lighting is provided for navigation and sense of security, whilst balancing the need to ensure that not too much excessive light is emitted into the surrounding areas, given the requirement for an open, ventilated facade.

Warm lights are to be used to create a softer and warmer environment within the structure and prevent light emitted from the building being too harsh.

Fixings are also to be carefully considered to direct and focus lights where needed as opposed to leaking to the surrounding environment.

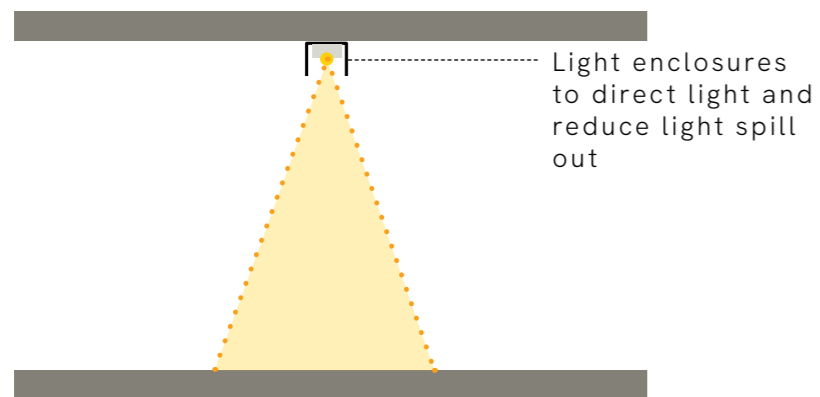

Directed light enclosures

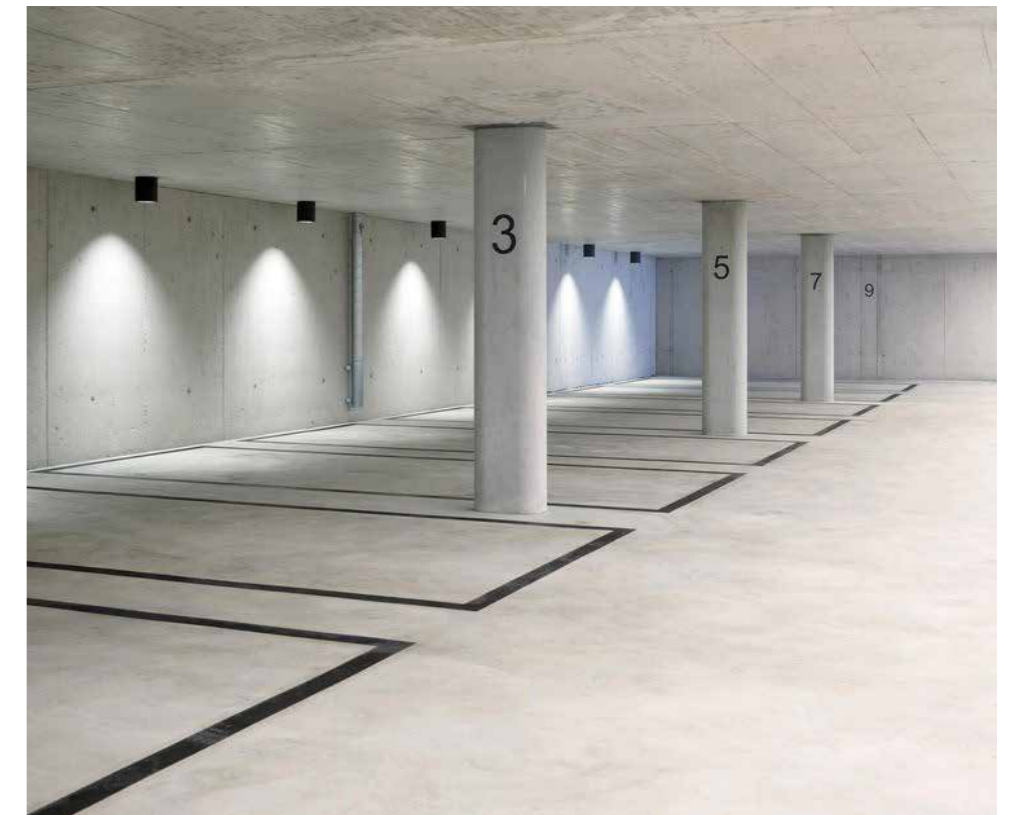

# MOBILITY HUB LIGHT POLLUTION MITIGATION STRATEGY

As the Mobility Hub is located on the eastern boundary of the site, it looks outward onto the greater Cambridge area. As such, light pollution needs to be carefully considered and mitigated to minimise excess light emitted into surrounding areas.

On the eastern edge, reinforced concrete crash barriers are to be raised to balustrade height. This creates a solid boundary to block out light emitting from car head and break lights.

The perforated cladding was used here in order to filter and reduce light emitted from the building further.

Light fixings within the building are also to be carefully considered, with lights housed in enclosures that direct lighting in specific directions and reduce spill-out from the building.

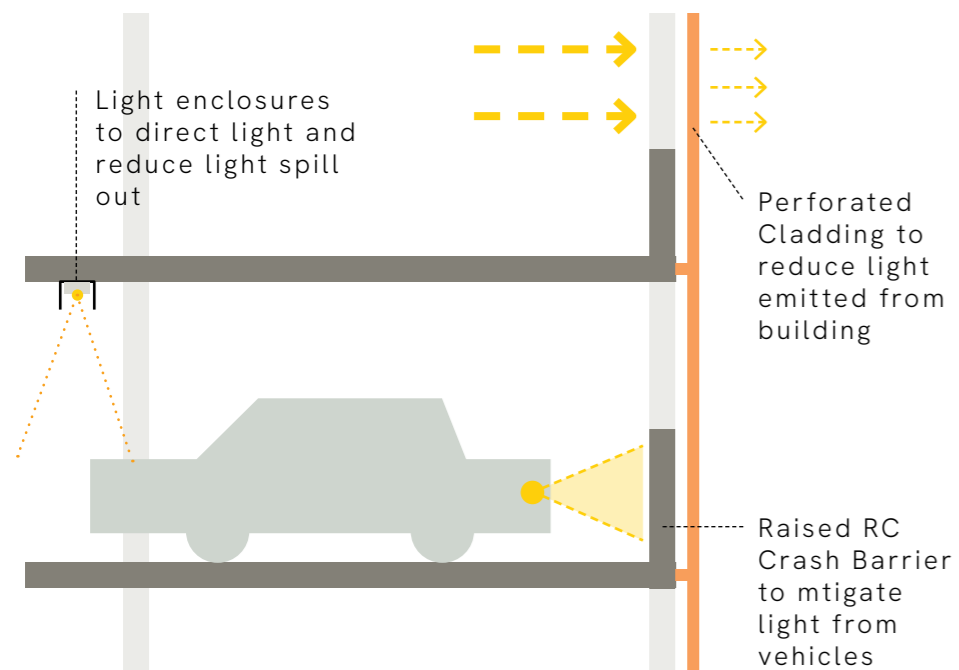

Eastern facade section



Raised RC crash barrier



Perforated facade cladding

